

INSTALLATION AND OPERATING INSTRUCTIONS

X-RAY FILM PROCESSOR DÜRR XR 04

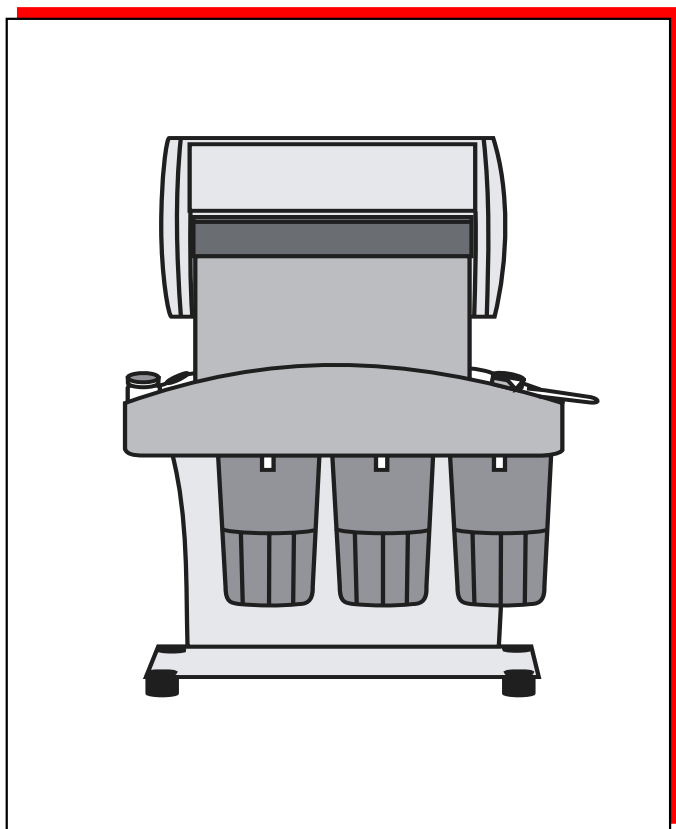

CONTENTS



Important information

1. Notes	4
1.1 Test of conformity	4
1.2 General Notes	4
1.3 General Safety Notes	4
1.4 Notes concerning Medical Appliances 5	
1.5 Electrical Safety Notes	5
1.6 Warnings and Symbols	5
2. Product information	6
2.1 Use in accordance with regulations	6
2.2 Use not in accordance with regulations	6
3. Model survey	6
4. Delivery schedule	6
4.2 Special extras	6
5. Technical data	6
7. Function description	7
6. Function principle	7



Installation

8. Installation Requirements	8
8.1 Installation site	8
8.2 Installation possibilities of the Processor	8



Gebrauch

9. Changing chemicals and water	9
9.1 Taking off daylight attachment	9
9.2 Cleaning film transport	10
9.3 Removing heater	11
9.4 Disposing of used chemicals	11
9.5 Mixing new chemicals	11
9.6 Assembling of the XR 04	12
10. Operation	12
11. Replacing film transport cogs	13
12. Wiring diagram	14



Disposal

13. Disposing of Appliance	14
---	----



IMPORTANT **INFORMATION**

1. NOTES

1.1 Test of conformity

This product was tested for conformity to the Guidelines 93/42/EWG of the European Union and has been found to satisfy all criteria of these guidelines.

1.2 General Notes

- These Installation and Operating Instructions form an integral part of the unit. They must be kept close to the unit at all times. Precise observance of these instructions is a pre-condition for use of the unit for the intended purpose and for its correct operation. New personnel must be made aware of the contents, and they should be passed on to future operating staff.
- Safety for the operator as well as trouble-free operation of the unit are only ensured if use is made of original equipment parts. Moreover, use may only be made of those accessories that are specified in the technical documentation or that have been expressly approved and released by Dürr Dental for the intended purpose.
- Dürr Dental cannot guarantee for the safety or proper functioning of this unit in the case where parts or accessories are used which are not supplied by Dürr Dental.
- Dürr Dental are only responsible for the equipment with regard to safety, reliability and proper functioning where assembly, resettings, changes or modifications, extensions and repairs have been carried out by Dürr Dental or an agency authorized by Dürr Dental and if the equipment is used in conformity with the Installation and Operating Instructions.
- These Installation and Operating Instructions conform to the relevant version of the equipment and the underlying safety standards valid at the time of going to press. All switches, processes, trade marks, software programs and appliances named in this document are registered names.

- Any reprinting of the technical documentation, in whole or in part, is subject to prior approval of Dürr Dental being given in writing.

1.3 General Safety Notes

This appliance has been designed and constructed by Dürr Dental so that correct usage of the appliance is virtually free of any possible injury or danger. In spite of this, we feel it is our duty to mention the following safety measures in order to prevent any possible danger.

- When using this appliance all local and relevant regulations must be observed! Converting or modifying the appliance in any way is strictly prohibited. In such cases, any and all guarantees immediately become invalid. The operation of modified appliances can be punishable by law. In the interests of trouble-free operation the operator is responsible for observing these regulations.
- Retain the packaging for possible return of the product to the manufacturers. Ensure that the packaging is kept out of the reach of children. Only the original packaging provides adequate protection during transport of the unit. Should return of the product to the manufacturers be necessary during the guarantee period, Dürr Dental accepts no responsibility for damage occurring during transport where the original packaging was not used!
- Before every use the operator must check the functional safety and the condition of the appliance.
- The operator must be knowledgeable in the operation of the appliance.
- The product is not designed to be used in medical treatment areas where there exists the danger of explosion. Areas where explosions could occur are those where flammable anesthetic material, skin cleansers, oxygen and skin disinfectants are present. This appliance is not to be used in areas where the atmosphere could cause fire.

1.4 Notes concerning Medical Appliances

- This product is a technical medical appliance and, as such, may only be operated by trained personnel, or persons who, as a result of specialist knowledge, are familiar with this type of appliance.
- Do not lie multi-socket units on the floor.
- Other systems should not be plugged into the same multi-socket unit.

1.5 Electrical Safety Notes

- The appliance may only be connected to an earthed safety socket.
- Before connecting the appliance to the power supply check that the electrical current and the frequency of the device as described on the appliance are compatible with that of the power supply.
- Check the appliance and the power supply cables for possible damage before switching on. Damaged cables, plugs and sockets must be replaced before use.
- Never touch open supply outlets and patients simultaneously.

1.6 Warnings and Symbols

In the Installation and Operating Instructions use is made of the following terms or symbols to denote information of special importance:



Information and/or mandatory regulations or prohibitions for the prevention of personal injury or substantial property damage



Warning of dangerous electrical voltage.



Special information regarding the economical use of the equipment and other information



CE-Labeling without Notified Body Number



Observe Installation and Operating Instructions!



Date of manufacture

2. PRODUCT INFORMATION

2.1 Use in accordance with regulations

The Dürr XR 04 X-ray developing machine is to be used exclusively for the automatic development of intra-oral X-ray films. Use in accordance with the regulations includes compliance with the instructions for mounting and usage as well as compliance with the provisions on setting up, installing and operating the machine, and on warranty. Use in accordance with the regulations also includes compliance with all legal provisions in force in the place where the machine is being used, with regard to work safety and the disposal of chemicals.

2.2 Use not in accordance with regulations

If the machine is used for a purpose other than the one stated in the regulations, the manufacturer shall not be legally liable for any damage arising as a result of same. In such cases, the user shall incur the risk.

3. MODEL SURVEY

X-ray film Processor XR 04

Model: 1740-01 (230 V)
1740-02 (110 V)
1740-03 (230 V) with heater
1740-04 (110 V) with heater

4. DELIVERY SCHEDULE

4.1 Optional extras

1 X-ray film Processor XR 04	1740-01
	1740-02
	1740-03
	1740-04
1 Securing set	1740-004-00
1 Chemical set	1307-080-00/40
1 Guarantee card	9000-464-86
1 Instruction manual	9000-600-05/01
1 Wall mounting	1740-011-00

4.2 Special extras

1 Heater, PC-board 110V	1740-994+00
1 Heater, PC-board 230V	1740-993+00
1 Table trestle	1740-012-00

5. TECHNICAL DATA

Model 1740 -	01	02	03	04
Voltage (V)	230	110	230	110
Current Consumption (mA)	35	-	400	-
Heater	w/o	w/o	with	with

Frequency (Hz)	50 - 60
Film run through time (adjustable min)	2 - 6
Total output (W)	85
Heat output (W)	40
Protection rating II, Protection type IP 21	
Heating up time (approx. min) (8 min / °C)	20 - 30
Weight (kg) without chemicals	7,5

6. FUNCTION PRINCIPLE

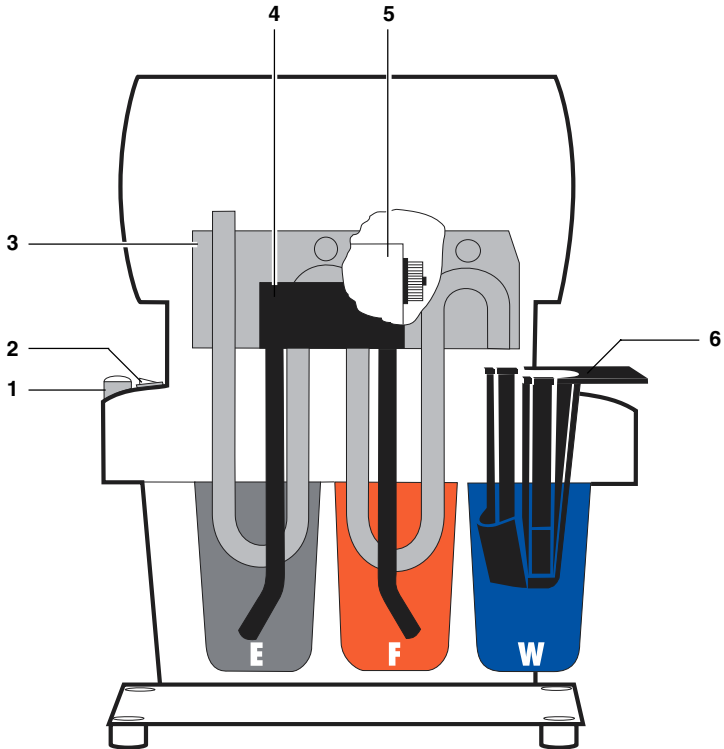

7. FUNCTION DESCRIPTION

Switch on main switch (2).
Heater for Developer/Fixer baths is started
(8 min/°C to 25°C bath temperature).

Switch on regulator (1) for the film transport and set the processing time (2-6 min.).

The films are carried via the film transporter through the Developer-/Fixer baths. The processed film remains in the perforated collector and should be taken out after approx. 5 mins.

- E** Developer bath
- F** Fixer bath
- W** Water bath
- 1** Processing time regulator
- 2** Unit switch ON/OFF
- 3** Film transporter
- 4** Heater
- 5** Transporter drive
- 6** Perforated collector



INSTALLATION

8. INSTALLATION REQUIREMENTS

8.1 Installation site

- The Processor XR 04 must be assembled in a dry, well ventilated room.



Never expose the Processor to direct sunlight!

With too strong sunlight pre-exposure of films and overheating of chemicals can occur.

8.2 Installation possibilities of the Processor

To obtain perfect development results, the installation area must be stable, flat and level.

- Assemble at or bring up to working height.
- Near a sink.
- Near a mains socket.

At a distance of approx. 1.5 m from the installation site of the XR 04, there should be a mains socket for the power cable of the XR 04. The mains socket should be sited so that the **power plug of the machine is easily visible and accessible without danger.**

(DIN 15990, para. 3.3.2 and 3.4)



For safety technical reasons the power connection should only be made shortly before putting the machine into operation.

Wall mounting see pict. 1.

- Mark the position for drilling the holes for the XR 04 (10) on the wall.
- Drill the holes, insert wall plugs and fit screws.
- Hang XR 04 on the screws, adjust as necessary, then tighten screws.

Table mounting see pict. 2.

Fit the upper part of the XR 04 onto the edge of the table and fasten it (11).

Table installation see pict. 3.

For this assembly it is necessary to have a separate table trestle (12), (not included in the delivery schedule)

Order no. 1740-012-00.

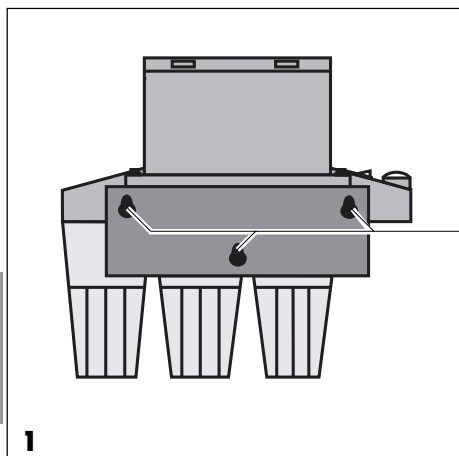

1

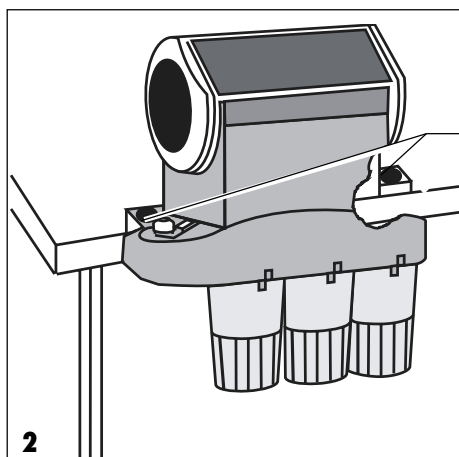

2

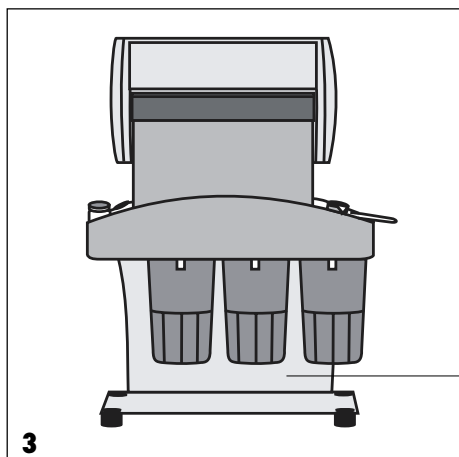

3

12

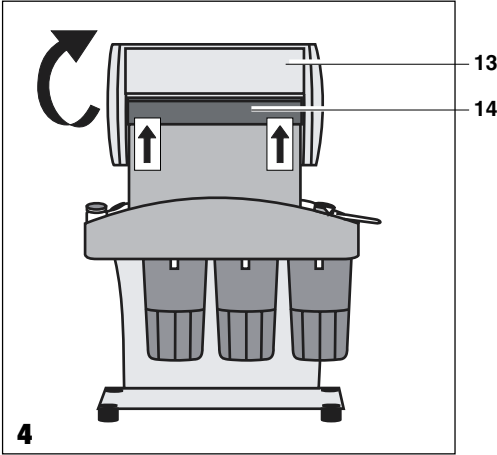

GEBRAUCH

9. CHANGING CHEMICALS AND WATER



Before working on opened equipment, pull out the mains plug.

- Change chemicals after approx. 200 films or after 3 weeks at the latest.
- Change water twice a week.



The information for changing the chemicals refer only when using "DÜRR Chemicals".

In Germany, as well as some other countries, used x-ray chemicals are classified as special waste and must be collected separately and disposed of.

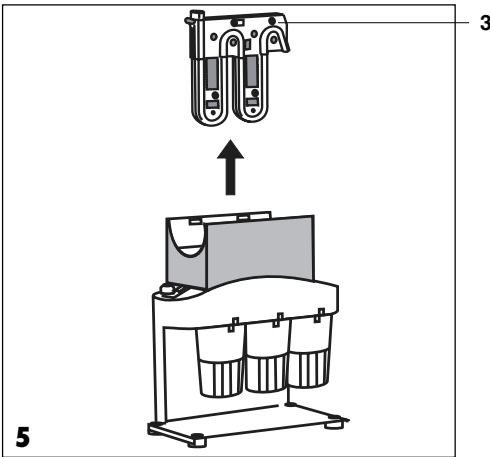

3

9.1 Taking off daylight attachment



Before taking off the daylight attachment: Pull out mains plug.

Push frame support (14) inwards with both thumbs. Swing daylight attachment (13) upwards and remove, see pict. 4.

9.2 Cleaning film transport

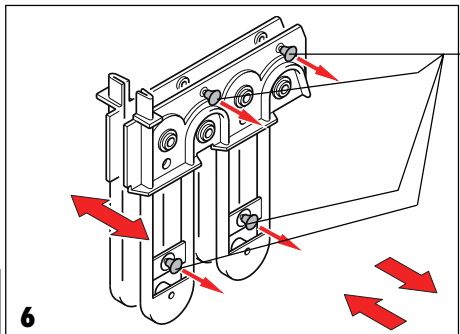

- Lift the film transport (3, Fig. 5) upwards to remove and rinse with warm water at approx. 40°C.
- If the film transport is very dirty it can be separated into two pieces and cleaned. Hereby :
- Pull the 4 snap fasteners of the film transport (16) out until they click into place.
- Using even pressure pull the top half from the bottom half (Fig. 6).
- Rinse both halves and, if necessary, clean with a brush.

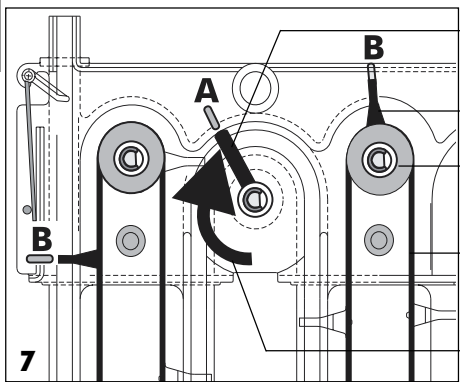

- **i** Please note that when cleaning the open film transport the toothed belt can get out of position. Therefore, before reassembling the film transport check the position of the cogs (19) and the toothed belt (20) as follows:
- The transport arm (17) should be **turned clockwise (21)** until it aligns with marking (A).
- The film carrier (18) should now be aligned with marking (B). If not, then correct the position of the toothed belt (20):

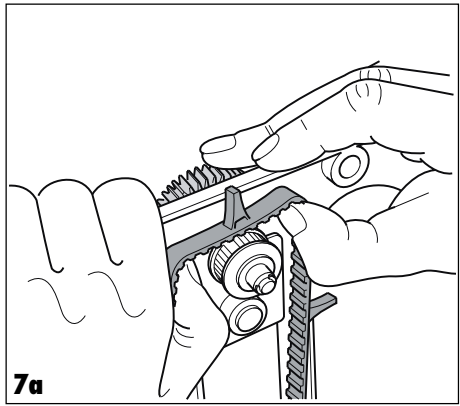

- Fig. 7a: Hold the film transport, so that the large, white cogs cannot turn.
- Fig. 7b: Lift the toothed belt (20) from the cogs (19), align the film carrier (18) with marking (B). Replace the toothed belt in the correct position and press onto the teeth of the cog wheel.

- **i** Here by take care that the toothed belt sits correctly on the cog with no overlap, otherwise there is the danger that the belt comes loose from the cogs during operation.
- Place the two halves of the film transport against each other and replace the snap fasteners.

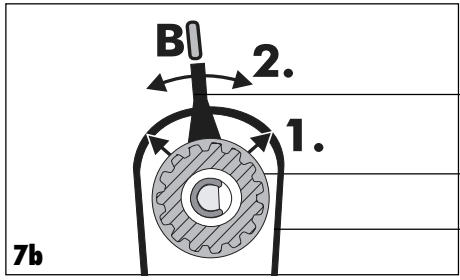

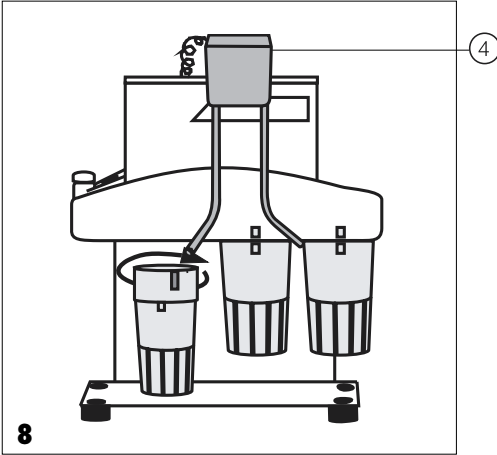

9.3 Removing heater



Only necessary with table-top model, otherwise the Developer-/Fixer containers cannot be removed.

Lift up Heater (4) and hang on frame.

9.4 Disposing of used chemicals

- Remove by rotating the 3 containers Developer (E)/Fixer (F)/Water (W) and very carefully take off downwards.
- Empty out chemical and water containers.
- Dispose of chemicals.
- Rinse containers with warm water and clean thoroughly.

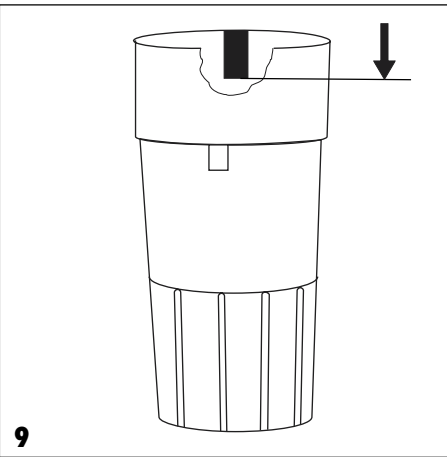

9.5 Mixing new chemicals



Fill containers only up to the markings.

Danger of "spillage" during insertion of containers.

- Pour developer up to black marking in container (E) and then fill up with fresh water to the upper marking. Insert container and rotate to fasten.
- Pour fixer up to the red marking in container (F) and then fill up with fresh water to the upper marking. Insert container and rotate to fasten.
- Fill container (W) with white markings up to the upper mark with fresh water. Insert container and rotate to fasten.

9.6 Assembling of the XR 04

- Replace heater (4) and film transporter (3), see pict. 5.

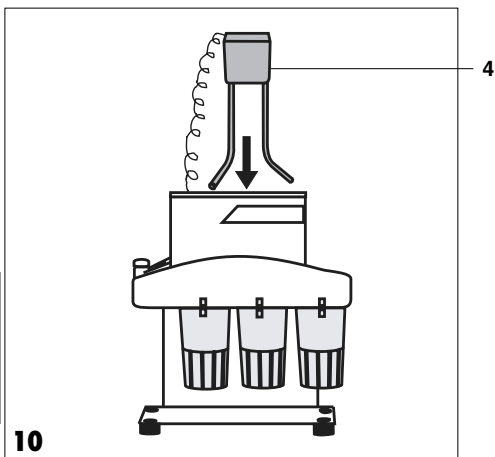

- Replace daylight attachment (13).

- Put the perforated collector (6) in the water container (6), see pict. 11 and right fold-in page.

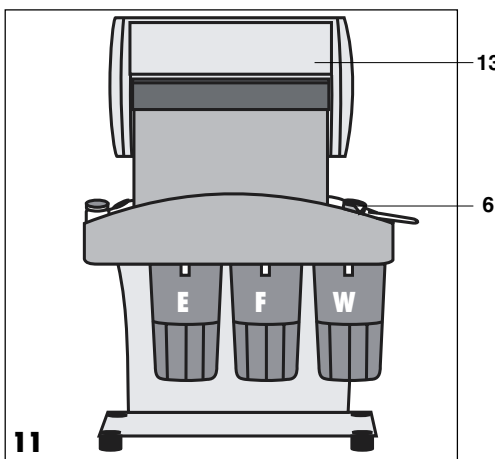

10. OPERATION

- Machine switch (2) **ON**.
Developer-/Fixer bath are being warmed up.
- Processor regulating timer (1) **ON**.
Set processing time, see pict. 12.
without heater:
Regulator on pos. 1
3 1/2 mins
with heater:
Regulator on pos. 2
2 1/2 mins.
- Place the wrapped exposed film in the daylight attachment.
- Insert hands into rubber cuffs and unwrap film.
- Enter film into the transporter system.
- Remove processed film from the water bath.
Washing: A min. of 5 mins in the perforated collector (6) (max. 1 hour)
- Processor regulating timer (1) **OFF**.

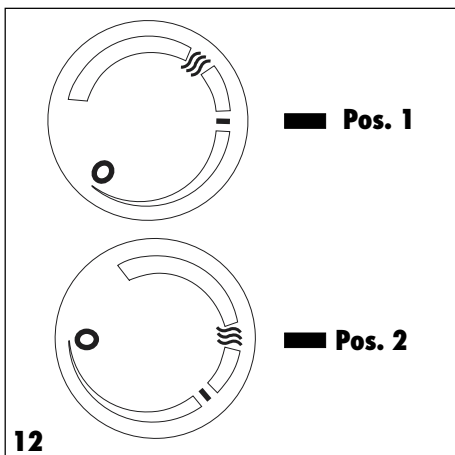

11. REPLACING FILM TRANSPORT COGS

- Remove the locking ring of the defective cog and pull the cog from the roller.
- Align the transport arm (A) with marking (B), press new cog into position and secure with the locking ring.
- Place the toothed belt cog (X) onto the film carrier roller (C) so that this appears as a D . The transport arms (A) must be aligned with the markings (B) and the film carrier (C) shows a D shape.
- Place the toothed belt in position and synchronise, see Point 9.2.

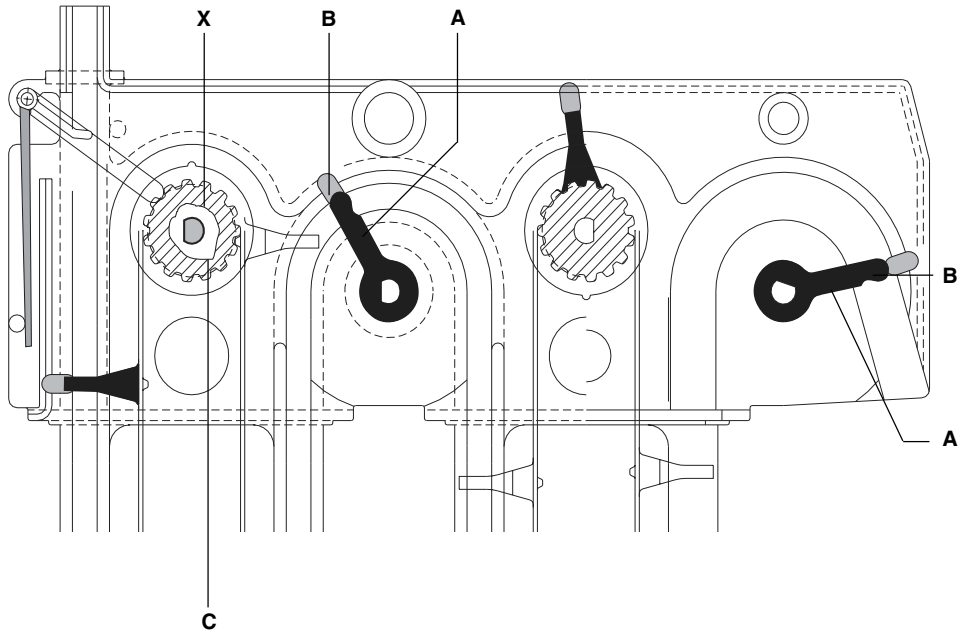

12. WIRING DIAGRAM

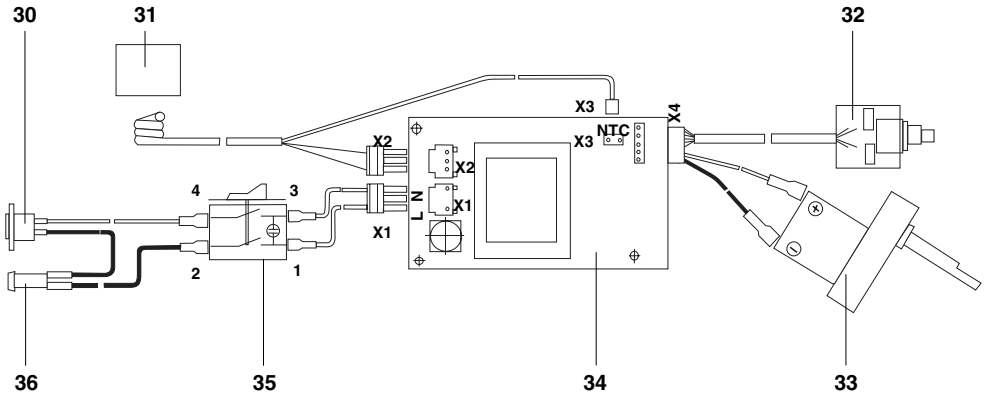

- 30 Mains
- 31 Heater
- 32 Processing time regulator
- 33 Drive motor
- 34 PC board
- 35 Unit switch
- 36 Fuse 100 mA T



DISPOSAL

13. DISPOSING OF APPLIANCE

The built-in electronic plate and components must be disposed of in the same way as electronic scrap metal.

The remaining structural components can be disposed in accordance with the relevant local regulations.